

# INSTALLATION INSTRUCTIONS

EQUIPMENT REQUIRED: LONG SOCKET EXTENSION  
 WIRING ACCESS LOCATION: SUV4  
 DRILL BITS:  
 HITCH REQUIRES 1/2" PIN AND CLIP  
 WRENCHES: (TIGHTEN ALL FASTENERS WITH TORQUE WRENCH) 15mm, 14mm, 17mm

## VEHICLE

CHEVROLET ASTRO VAN  
 GMC SAFARI VAN  
 STANDARD AND EXTENDED

3500 LB MAX GROSS TRAILER WT  
 300 LB MAX TONGUE WEIGHT  
 DO NOT EXCEED TOWING VEHICLE RATINGS

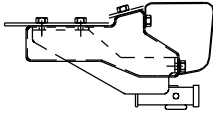

HITCH SHOWN IN PROPER POSITION

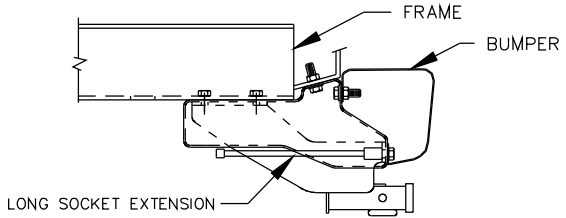

FIGURE 1

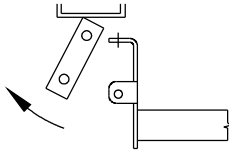
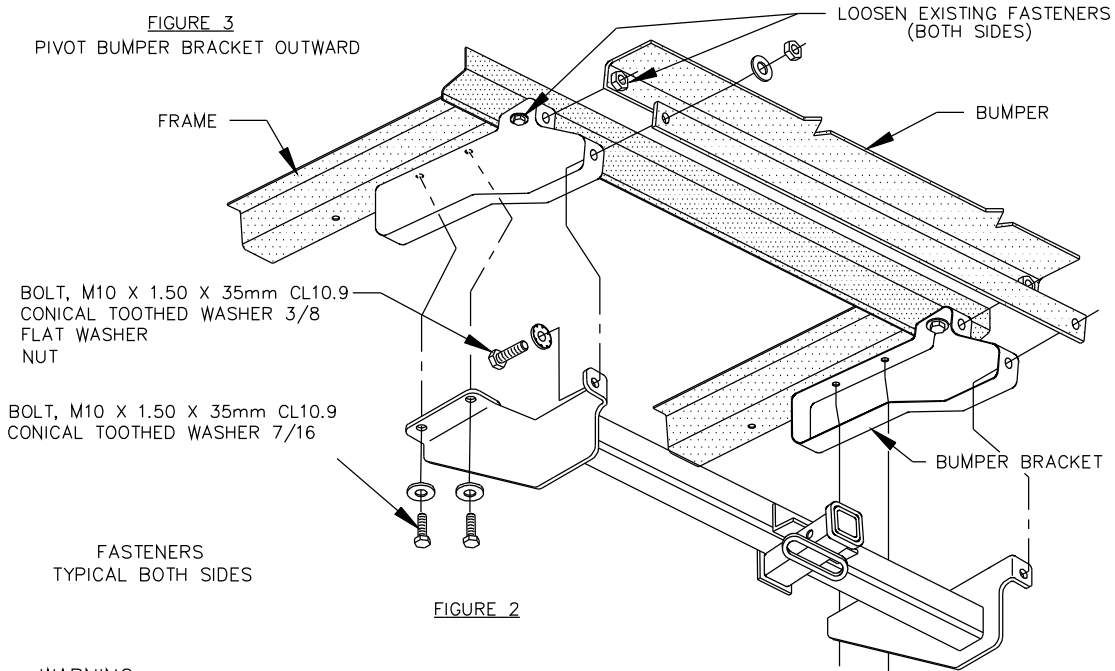

FIGURE 3

PIVOT BUMPER BRACKET OUTWARD



BOLT, M10 X 1.50 X 35mm CL10.9  
 CONICAL TOOTHED WASHER 3/8  
 FLAT WASHER  
 NUT

BOLT, M10 X 1.50 X 35mm CL10.9  
 CONICAL TOOTHED WASHER 7/16

FASTENERS  
 TYPICAL BOTH SIDES

FIGURE 2

### WARNING:

ON STANDARD VANS, A SPARE CANNOT BE STOWED UNDER VEHICLE WITH HITCH INSTALLED.

1. REMOVE (2) FORWARD BUMPER BRACKET TO FRAME BOLTS AND (1) BOTTOM BUMPER BRACKET TO BUMPER BOLT, ON EACH SIDE, SEE FIGURE 2. LOOSEN REMAINING BUMPER BRACKET BOLTS. RETURN BOLTS TO VEHICLE OWNER FOR REINSTALLATION IN THE EVENT THAT THE HITCH IS REMOVED FROM THE VEHICLE.

NOTE: BUMPER BRACKETS REMAIN IN PLACE WITH HITCH INSTALLED.

2. WHILE PIVOTING THE BUMPER BRACKETS OUTWARD, LIFT THE RECEIVER INTO POSITION, CENTERING THE SLOTS IN THE SIDE BRACKETS OVER THE WELDNUTS IN THE FRAME, SEE FIGURE 3.
3. INSTALL FASTENERS AS SHOWN IN FIGURE 2. A SOCKET AND LONG EXTENSION IS NECESSARY TO TIGHTEN THE LOWER BUMPER BOLTS, SEE FIGURE 1.

TIGHTEN ALL M10 FASTENERS TO 42 LB.-FT.

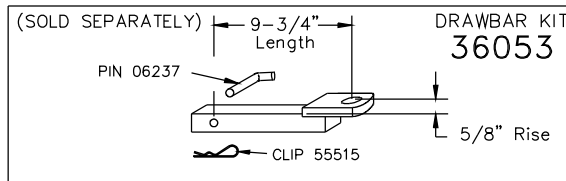

USE ONLY THE DRAWBAR SHOWN FOR CORRECT BUMPER CLEARANCE AND HEIGHT.  
 DRAWBAR MUST BE USED IN THE RISE POSITION ONLY.

THIS PRODUCT COMPLIES WITH SAFETY SPECIFICATIONS AND REQUIREMENTS FOR CONNECTING DEVICES AND TOWING SYSTEMS OF THE STATE OF NEW YORK, V.E.S.C. REGULATION V-5 AND SAE J684.

APPROX WEIGHT (LB.)	FASTENER KIT
28	F36198

NOTE: Check hitch frequently, making sure all fasteners and ball are properly tightened. If hitch is removed, plug all holes in trunk pan or other body panels to prevent entry of water and exhaust fumes. A hitch or ball which has been damaged should be removed and replaced. Observe safety precautions when working beneath a vehicle and wear eye protection. Follow car maker's specs for maximum trailer weight and tongue weight. Do not cut access or attachment holes with a torch.



PRINTED IN MEXICO